

# 500V SERIES DECK & MULE BELT QUICK-REFERENCE MAINTENANCE SCHEDULE

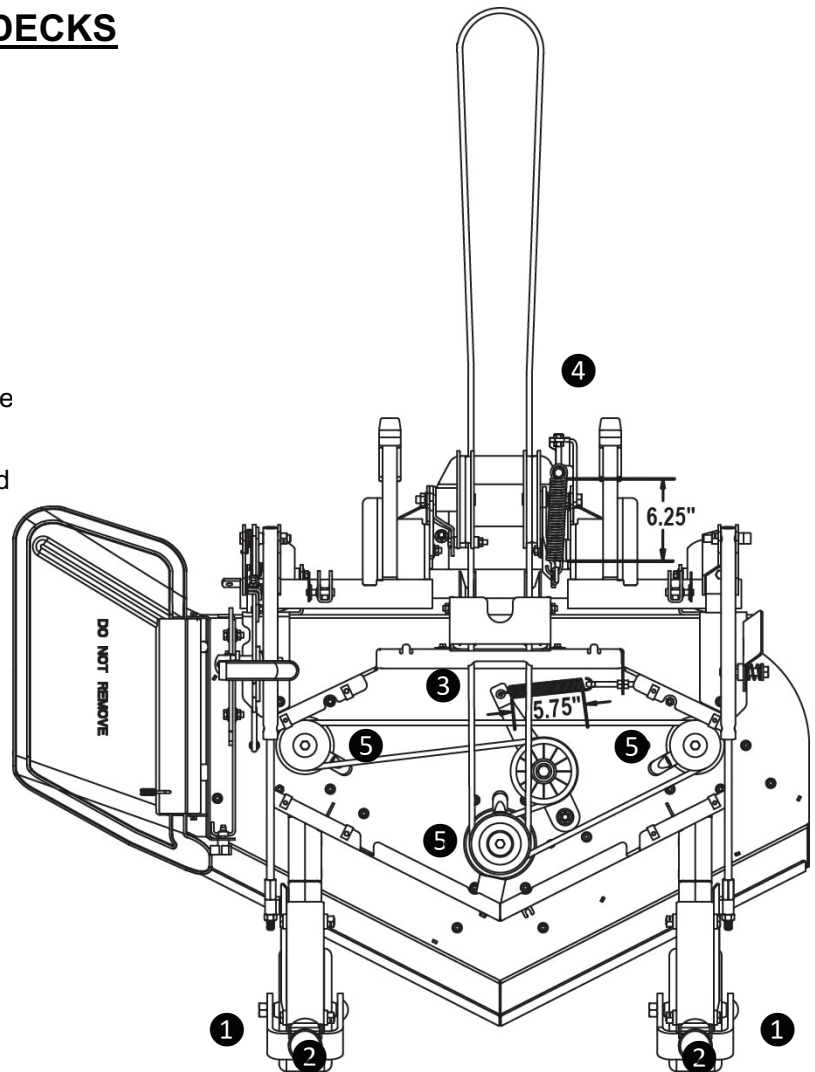

## 3242 (524V/525V) & 3252 (526V) DECKS

- 1 **Front Wheel Bearings (2):** 8 hours (1 to 2 strokes of grease)
- 2 If wheel wobble develops, apply 75 ft./lbs. torque on wheel fork upper nuts
- 3 Check **Deck Belt Tension** every 100 hours. Adjust spring to 5.75".
- 4 Check **Mule Belt Tension** every 100 hours. Adjust spring to 6.25" Replace belts that have excessive wear.
- 5 Non-greaseable **blade spindles** have sealed upper and lower bearings.



## GENERAL SERVICE RECOMMENDATIONS

### Other Deck Notes:

- Keep discharge shield in working position
- Tighten four bolts on each deck wheel assembly every 100 hours
- Semi-pneumatic tires on 33 & 34 Series Decks – No air pressure necessary
- Sharpen & balance blades daily for quality of cut and fuel economy
- A clean deck allows drive components to run cooler. Do not allow clippings or debris to build up. **Do Not Power Wash.** Water will cause drive components to rust and cause premature failure of bearings and belts. **Clean with air or damp cloth using mild cleanser.**



The Grasshopper Company • 105 Old U.S. Highway 81  
P.O. Box 637 • Moundridge, KS • 67107 U.S.A.  
T: **620-345-8621** • [grasshoppermower.com](http://grasshoppermower.com)

