

# M1 SERIES QUICK-REFERENCE MAINTENANCE SCHEDULE

See Operator's Manual for details on specific model in use.

Turn off engine & remove key prior to servicing unit. Replace all safety shielding removed during service procedures prior to operating machine.

- 1 **Front Wheel Bearings:** Grease every 8 hours
- 2 **Blade Spindles:** All spindles with sealed upper and lower bearings: Grease every 300 hours or semi-annually. To grease, remove cone to expose relief valve hole; apply grease until grease escapes from relief valve hole, normally 3 to 5 strokes. (The Discharge Spindle Assembly at the rear of 4XRD decks requires no lubrication.)

S/N 5941884 & below (models with one or no sealed bearings): Grease every 40 hours. 4 to 5 strokes is normal. Tip cover removal not necessary to access zerks.

- 3 Keep **Discharge Shield** in working position.
- 4 Inspect **Deck Belt** every 100 hours for wear; and proper spring tension on idler: 5.75"
- 5 Use **Battery Minder** if unit is to sit idle more than 30 days. (Remove Battery Minder before using battery charger on low or dead battery;
- 6 Inspect **Rear Idlers** for proper spring tension every 100 hours: Hydro drive: 5-3/4"; Mule drive: 5-1/4"

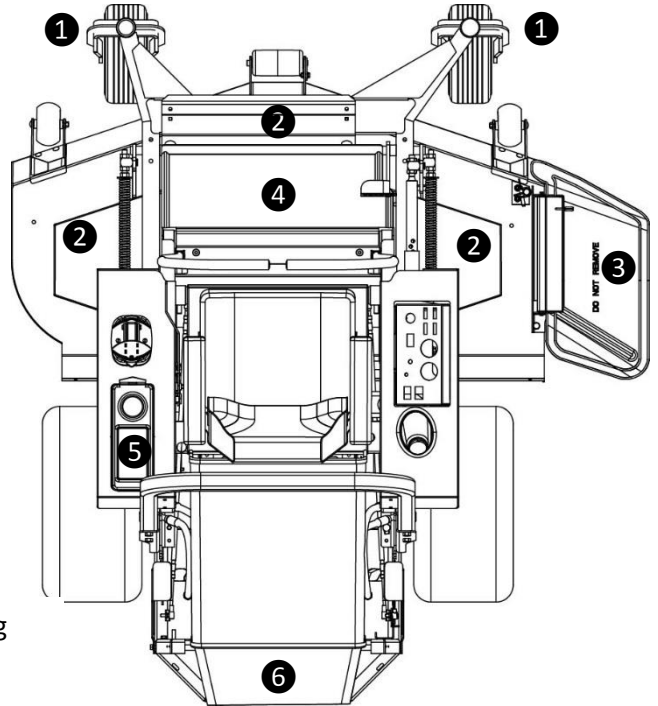

## GENERAL SERVICE RECOMMENDATIONS

**CHECK OPERATOR PRESENCE SYSTEM** before each operation. Engine shut-off switches are in seat, levers, parking brake and PTO switch.

**CHECK TIRE PRESSURES DAILY.** Don't overinflate. Refer to decal on rim for proper pressure. If decal is missing, refer to manual. Turf drive tires: 9 psi; Front tires: 12 psi. Use Grasshopper Premium Twin Fiber Homogenized Tire Sealant to prevent small leaks.

**CLEAN WITH AIR.** Do not use high pressure water or steam to clean engine or drive compartment. Water and cleaning detergent forced into switches and electrical connections may cause rust and corrosion, possibly leading to component and safety circuit failure. Use low pressure compressed air, vacuum cleaner or air blower to remove foreign material from the engine, deck and drive compartment.

**M1 HYDROSTATIC TRANSMISSIONS** require very little service. Check fluid level every 100 hours (raise seat to locate dipstick) and change fluid and filter every 1,000 hours. Use 7-micron absolute filter no. 100855 and 5.5 quarts of CoolTemp HydroMax™ fluid part #345044-quart; #345046-2 gallon. System is self-bleeding. No bleeding necessary.

**SHARPEN & BALANCE BLADES DAILY** (every 8 hours) for optimum cutting quality and fuel economy.

Use OEM parts, especially belts, blades and filters. OEM parts are engineered to work in conjunction with the specific system for which they are designed. If aftermarket parts fail to protect the equipment, more will be spent on repairs than what is saved on cheaper parts and they may void warranty.